

**EET203 : MEASUREMENTS AND  
INSTRUMENTATION  
MODULE I**

**PREPARED BY:**

**MS. SOUMYA C**

**ASST. PROF, EEE**

**JECC**

# SYLLABUS

## Module I

Measurement standards – Errors -Types of Errors - Statistics of errors, Need for calibration.

Classification of instruments, secondary instruments – indicating, integrating and recording operating forces - essentials of indicating instruments - deflecting, damping, controlling torques.

Ammeters and voltmeters - moving coil, moving iron, constructional details and operation, principles shunts and multipliers – extension of range.

# Measurement - Introduction

- Measurement is the act, or the result of a quantitative comparison between given quantity (whose magnitude is unknown) and a quantity of same kind chosen as a standard.
- The device used for comparing the unknown quantity with the unit of measurement or a standard quantity is called a measuring instrument.
- Instrumentation is the technology of using instruments to measure and control the physical and chemical properties of materials.

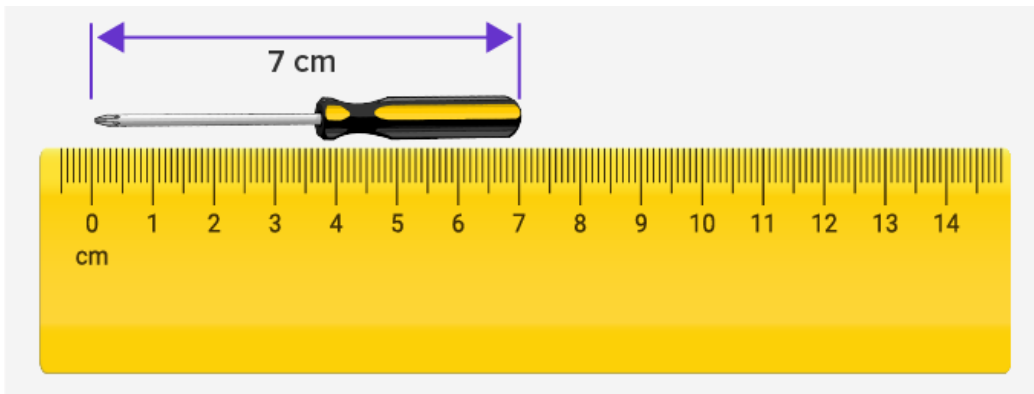

- **Measurand** refers to the physical quantity or property that is being measured in a particular scientific or engineering process.

Measurand may be:

- Fundamental Quantity. Eg: length, mass, time, etc.
- Derived Quantity. Eg: Velocity, acceleration, pressure, etc.

## Significance of Measurements

- Measurements play a very significant role in every branch of scientific research and engineering processes. Measurements are the foundation of the entire field of automation or automatic control.
- Through measurements a product can be designed, or a process can be operated with maximum efficiency, minimum cost, and with desired degree of reliability and maintainability.

# Methods of measurement

Basically, there are two methods of measurements

1. Direct comparison methods
  2. Indirect comparison methods
- **Direct comparison methods:** The unknown quantity is determined by direct comparison with a standard of the given quantity. Quantity to be measured is directly determined from the measuring device. Eg: Measurement of length by a scale.
  - Direct comparison methods of measurement are simple, but it is not always possible, feasible and practicable to use them. The involvement of a person in these methods make them inaccurate and less sensitive.
  - **Indirect comparison methods:** The quantity to be measured is determined indirectly by measuring other parameters. Eg: Resistance measurement from voltmeter ammeter method,  $R = V/I$

# Elements of Generalized measurements system

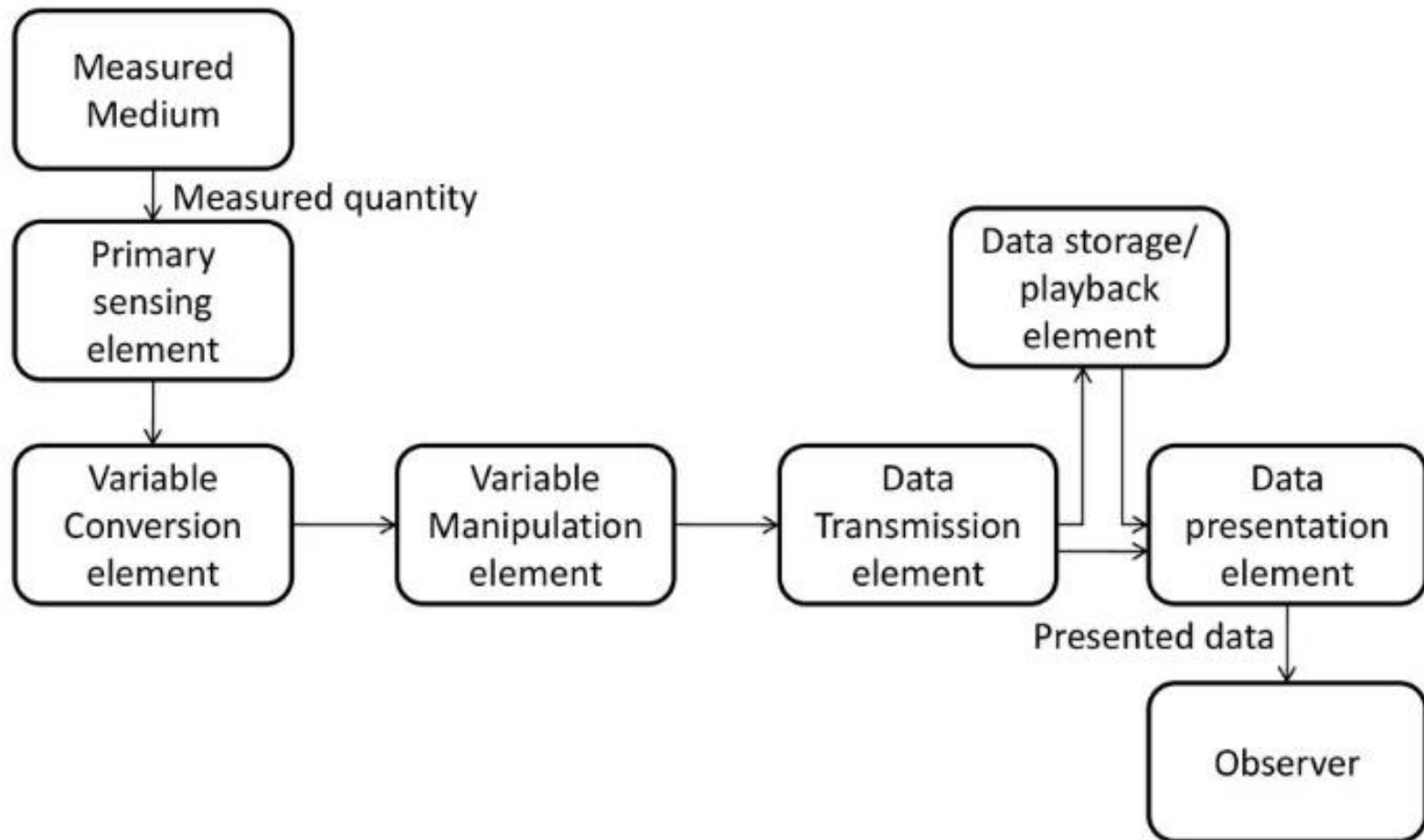

## Primary Sensing Element

- The quantity under measurement (measurand) is first detected by primary sensor or detector followed by conversion of measurand into an analogous electrical signal. This is done by a transducer.
- A transducer is defined as a device which converts a physical quantity into an electrical quantity.
- The first stage of a measurement system is known as a detector transducer stage.

## Variable Conversion Element

- The output signal of the variable sensing element may be any kind. It may be a voltage, frequency or some other electrical parameters. Sometimes, the output from the sensor is not suited to the measurement system.
- This part converts this output signal from the sensor to some other suitable form while preserving the information content of the original signal. Eg: Analog to digital converter

## Variable Manipulation Element

- Variable manipulation means a change in numerical value of the signal. The function of a variable manipulation element is to manipulate the signal presented to this element while preserving the original nature of the signal.

Ex: a voltage amplifier acts as a variable manipulation element.

- The amplifier accepts a small voltage signal as input and produces an output signal which is also voltage but of greater magnitude. Element that follows primary sensing element in any instrument or measurement system is called data conditioning element.

## Data Transmission Element

- There are several situations where the elements of an instrument are physically separated. In such situations it becomes necessary to transmit data from one element to another.



- The element that performs this function is called a data transmission element. Eg: Satellites or the airplanes are physically separated from the control stations at earth.

## Data Presentation Element

- The function of data presentation element is to convey the information about the quantity under measurement to the personnel handling the instrument or the system for monitoring, control, or analysis purposes. The information conveyed must be in a convenient form.

## Data storage and playback element

- Some applications requires a separate data storage and playback function for easily rebuild the stored data based on the command. The data storage is made in the form of pen/ink and digital recording. Examples, Magnetic tape recorder/ Reproducer, X-Y recorder, Optical Disc recording etc.

# Example of Generalized Measurement System

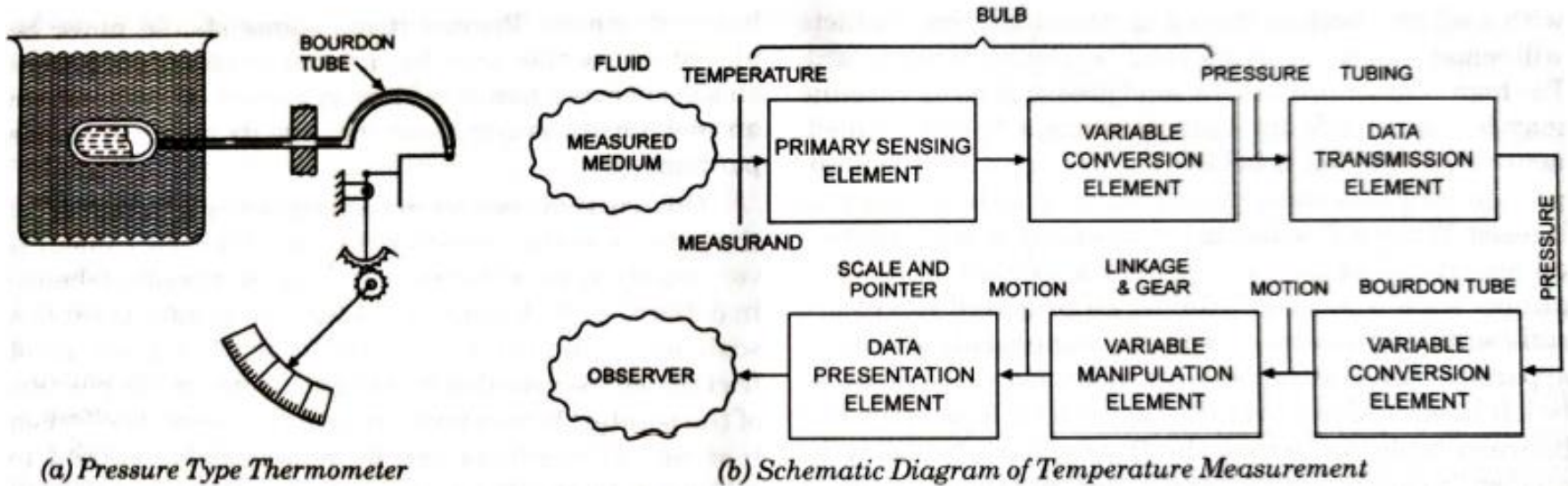

- Primary Sensing Element & Variable Conversion Element - Bulb
- Variable Conversion Element – Bourden Tube
- Variable Manipulation Element – Linkage and Gear
- Data Presentation Element – Scale and Pointer

# Example of Generalized Measurement System

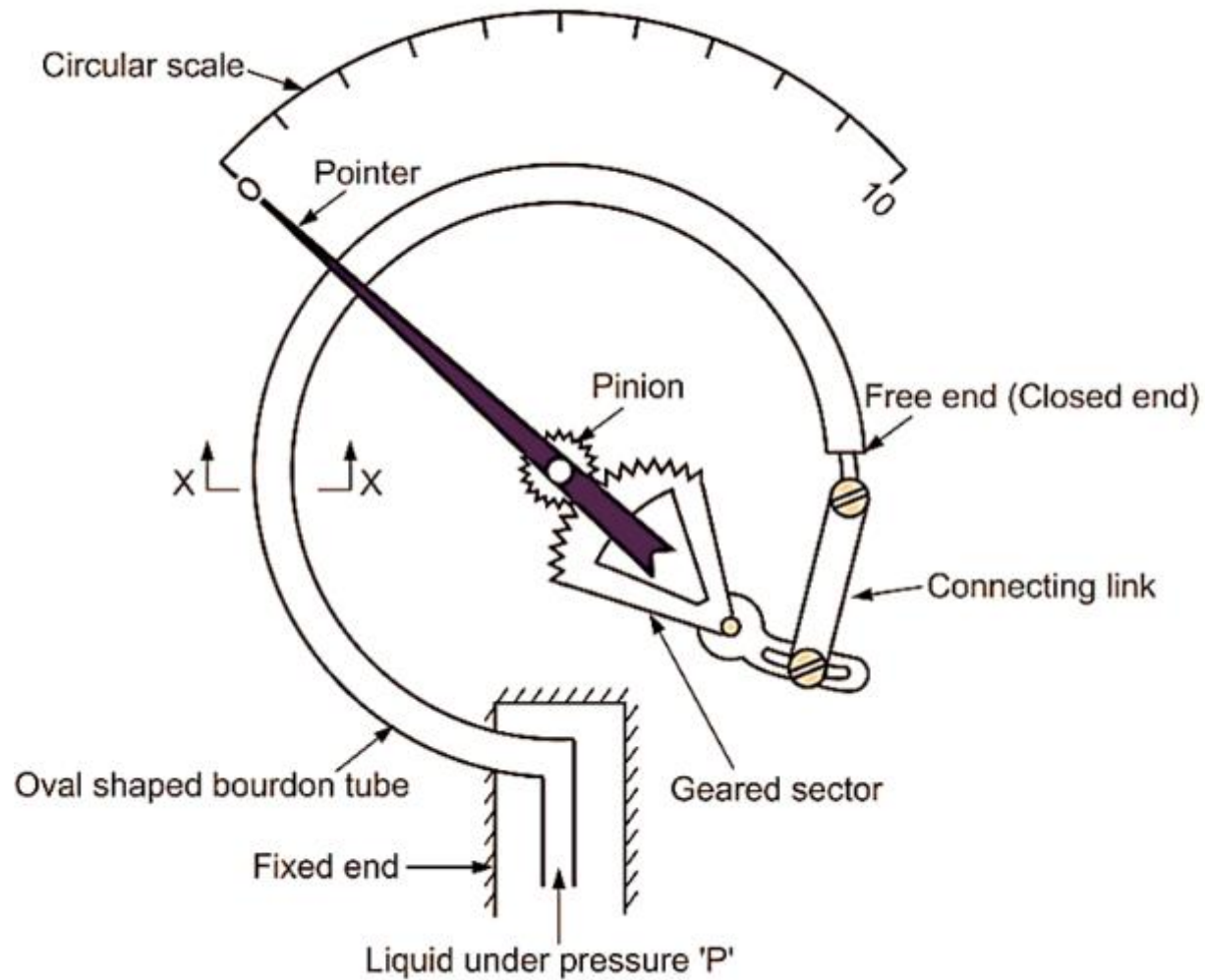

# Example of Generalized Measurement System

## Bourdon Tube Pressure Gauge

- In this measurement system, bourdon tube is acting as primary sensing and variable conversion element. The input pressure is sensed and converted into small displacement by a bourdon tube. On account of input pressure the closed end of the tube is displaced.
- The closed end of bourdon tube is connected through mechanical linkage to a gearing arrangement. The small displacement signal can be amplified by gearing arrangement and transmitted by mechanical linkages and finally it makes the pointer to rotate on a large angle of scale.
- If it is calibrated with known input pressure, gives the measurement of the pressure signal applied to the bourdon tube in measurand

# Applications of Measurement Systems

- The instruments and measurements are employed for the following three applications:

## 1. Monitoring of processes and operations

- In these types of applications, the measuring instruments simply indicate the value of the parameter under study and do not serve any control function.

Ex1: Energy meters installed at home.

Ex2: Ammeters and voltmeters indicating the instantaneous value.

## 2. Control of processes and operations

- There is a strong association between measurements and control. The instruments find a very useful application in the automatic control systems.
- Ex: Refrigeration system which employs a thermostatic control.

### 3. Experimental engineering analysis

- Several engineering problems can be solved by experimental methods.
- Following are the uses of experimental engineering analysis:
  - a) To determine system parameters, variables and performance indices
  - b) To formulate the generalized empirical relationship in cases where there is no proper theoretical backing.
  - c) To test the validity of theoretical predictions.
  - d) To solve mathematical relationships with the help of analogies.

## Measurement Standards

- Standard means known **accurate measure of a physical quantity**. Depending upon the degree of accuracy required for the work, the standards are subdivided into following four categories.
  - Primary Standards (Reference Standards).
  - Secondary Standards (Calibration Standards).
  - Tertiary Standards (Inspection Standards).
  - Working Standards (Workshop Measuring Standards).

### Primary Standards (Reference Standards)

- The primary standard is also known as Master Standard and is preserved under the most careful conditions. These standards are not commonly in use. They are maintained at National Standard Laboratories at different countries. The main function of the primary standard is calibration and verification of secondary standards.

## Secondary Standards (Calibration Standards)

- The secondary standard is more or less similar to the primary standard. They are nearly close in accuracy with primary standards. The secondary standard is compared at regular intervals with primary Standards and records their deviation. They are used occasionally for comparing the tertiary standards.

## Tertiary Standards (Inspection Standards)

- The Tertiary standard is the first standard to be used for reference purpose in workshops and laboratories. They are used for comparing the working standards. These are not used as frequently and commonly as the working standards but more frequency than secondary standards.

## Working Standards (Workshop Measuring Standards)

- The working standard is used for actual measurement in workshop or laboratories by the workers.



- These standards should also be as accurate as possible to the tertiary standard. But sometimes, lower grades of materials can be used for their manufacturing to reduce cost.

## Errors and Types

- Errors and uncertainties are inherent in the process of making any measurement and in the instrument with which the measurements are made.

## Types of Errors

- The errors in measurement may happen from the various sources which are generally categorized into the following types.
  1. Gross Errors
  2. Systematic Errors
  3. Random Errors

## 1. Gross Errors

- The gross error occurs because of the human mistakes. Manual errors in reading instruments or recording and calculating measurement results are known as Gross errors.
- Generally, these errors occur during the experiments, where the experimenter might read or record a value different from the actual one, probably due to poor sight.

Ex: One may write the calculation result of  $0.2 \times 0.5$  as 0.01 instead of 0.1

- Although it is probably impossible to eliminate the gross error completely, we can minimize it by adopting the following means.
  1. Immense care should be taken while taking the reading and recording the data.
  2. Two, three or even more readings should be taken for the quantity being measured.

## 2. Systematic Errors

- Errors which occur due to changes in environment conditions, instrumental reasons or wrong observations. These errors are of three types
  - a) Instrumental Errors
  - b) Environmental Errors
  - c) Observational Errors

### Instrumental Errors

- These errors occur due to Shortcomings in the instruments, Improper use of instruments and Loading effect of the instrument.
- Inherent Shortcomings of Instruments – Such types of errors are inbuilt in instruments because of their mechanical structure. They may be due to manufacturing, calibration or operation of the device. These errors may cause the error to read too low or too high.

For example – Weak spring ,Friction etc.

(b) Misuse of Instrument – The error occurs in the instrument because of the fault of the operator. A good instrument used in an unintelligent way may give an erroneous result. For example –failure to adjust the zero of instruments.

(c) Loading Effect – It is the most common type of error which is caused by the instrument in measurement work. For example, when the voltmeter is connected to the high resistance circuit it gives a misleading reading

Example for loading effect:-

- A voltmeter always connects in parallel to electronic components for measuring the voltage. Practical voltmeters are designed to possess very high internal resistance (usually 10 or 20  $M\Omega$ ). When voltmeter connects to a very high external resistance the overall resistance of circuit changes. For example, a voltmeter with 10  $M\Omega$  internal resistance while connected in parallel to 7.5  $M\Omega$  resistors will change overall resistance to 4.28  $M\Omega$ .

## Environmental Errors

- These errors are due to the external condition of the measuring devices.
- Such types of errors mainly occur due to the effect of temperature, pressure, humidity, dust, vibration or because of the magnetic or electrostatic field.
- The corrective measures employed to eliminate or to reduce these undesirable effects are
  - Make sure to keep the ambient physical conditions constant.
  - Use instruments which have ample immunity to effects of environmental changes.
  - Use different techniques, for example sealing the instrument, to eliminate the effects.
  - By applying the computed corrections.

## Observational Errors

- Such types of errors are due to the wrong observation of the reading.
- These errors occur due to a mismatch between a line of vision of the observer and the pointer above the instrument scale.
- This is also termed as Parallax error which occurs when the observer is unable to have a vision aligned with the pointer.
- Since they occur on Analog instruments, using digital display can eliminate these errors.

### 3. Random Errors

- These errors occur due to a group of small factors which fluctuate from one measurement to another. The situations or disturbances which cause these errors are unknown, hence they are termed as Random errors.

## Definitions Relating to Measuring Instruments

1. True Value - True value of a quantity to be measured may be defined as the average of an infinite number of measured values when the average deviation due to various contributing factors tends to zero. This is an ideal case.
2. Indicated Value - It is the magnitude of a variable/quantity indicated by a measuring instrument.
3. Range or Span - The minimum and maximum values of a quantity for which an instrument is designed to measure is called its range or span.
4. Threshold/Dead Zone - If the instrument input is increased very gradually from zero there will be some minimum value below which no output change can be detected. This minimum value defines the threshold of the instrument. Smallest measurable input.

5. Dead Time - It is the time before the instrument begins to respond after the measurand quantity has been changed.
6. Resolution - If the input is slowly increased from some arbitrary input value(nonzero), it will again be found that output does not change at all until a certain increment is exceeded. This increment is called resolution. Smallest measurable input change.
7. Sensitivity - It is defined as the ratio of the changes in the output of an instrument to a change in the value of the quantity to be measured. If an ammeter gives a deflection of 45 degree for a current of 5 A then its sensitivity is 9 degree/A.
8. Drift - Undesired change in the output-input relationship over a period of time. No drift means that with given input the measured value do not vary with time.
9. Tolerance - It is the range of inaccuracy which can be tolerated in measurements.



10. Accuracy - Accuracy is the ability of the instrument to measure the accurate value. In other words, it is the closeness of the measured value to a standard or true value.
11. Precision - Precision means two or more values of the measurements are close to each other. The precision is used for finding the consistency or reproducibility of the measurement.



Accurate and Precise



Precise, But Not Accurate



Accurate, But Not Precise



Neither Accurate Nor Precise

## Static Characteristics of Measuring Instrument

- Accuracy, Precision, Sensitivity, Resolution, Threshold/Dead Zone , Range or Span , Drift, Repeatability, Reproducibility, Loading Effect

## Statistics of Errors

- This method is used to estimate the value or error when unpredictable or random errors are dominant. Statistical analysis will give the deviation from the true value. It is employed by taking a large number of readings of a particular parameter and calculations are made in the following ways.

### Arithmetic Mean

- The most probable value of a measured variable is the arithmetic mean of the number of readings taken. The arithmetic mean of  $n$  measurements at a specific count of the variable  $x$  is given by the expression

$$\text{Arithmetic Mean, } \bar{x} = \frac{x_1 + x_2 + x_3 + \dots + x_n}{n} = \frac{1}{n} \sum_{i=1}^n x_i$$

where,

$x_i$  is the  $i^{\text{th}}$  reading taken

$n$  is the total number of readings

## Deviation from the Mean

- This is the deviation of a given reading from the arithmetic mean of the group of readings.
- Let the deviation of the first reading,  $x_1$ , is called  $d_1$  and that of the second reading  $x_2$  is called  $d_2$ , and so on. The deviations from the mean can be expressed as

$$d_1 = x_1 - \bar{x},$$

$$d_2 = x_2 - \bar{x},$$

$$\vdots$$

$$d_n = x_n - \bar{x}$$

- The deviation may be positive, negative or zero.
- The algebraic sum of all the deviations must be zero.

## Average Deviation

- The average deviation is an indication of the precision of the instrument used in measurement.
- Average deviation is defined as the sum of the absolute values of the deviation divided by the number of readings.
- The absolute value of the deviation is the value without respect to the sign. Average deviation may be expressed as

$$\text{Average Deviation, } D_{av} = \frac{|d_1| + |d_2| + |d_3| + \dots + |d_n|}{n} = \frac{1}{n} \sum_{i=1}^n |d_i|$$

where,

$|d_i|$  is the absolute value of the deviation of  $i^{\text{th}}$  reading from mean  
 $n$  is the total number of readings

## Standard Deviation

- The standard deviation of an infinite number of data is the Square root of the sum of all the individual deviations squared, divided by the number of readings.
- It may be expressed as

$$\text{Standard Deviation, } \sigma = \sqrt{\frac{d_1^2 + d_2^2 + d_3^2 + \dots + d_n^2}{n}} = \sqrt{\frac{1}{n} \sum_{i=1}^n d_i^2}$$

where,

$d_i$  is the deviation of  $i^{\text{th}}$  reading from mean

$n$  is the total number of readings

- The standard deviation is also known as root mean square deviation and is the most important factor in the statistical analysis of measurement data. Low value for standard deviation means better measurement values. For small readings ( $n < 20$ ), the denominator is frequently expressed as  $(n-1)$  to obtain a more accurate value for the standard deviation, and denoted by  $s$ .

## Calibration & It's Need

- The calibration is the process of checking the accuracy of the result by comparing it with the standard value.
- In other words, calibration checks the correctness of the instrument by comparing it with the reference standard.
- It helps us in determining the error occur in the reading and adjusts the values for getting the ideal reading.
- The goal of calibration is to minimize any measurement uncertainty by ensuring the accuracy of test equipment.
- Calibration quantifies and controls errors or uncertainties within measurement processes to an acceptable level.

# Classification of Measuring Instruments

The measuring instrument categorized into three types:

- a) Mechanical Instrument - The mechanical instrument is used for measuring the physical quantities. Ex:- Vernier caliper
- b) Electrical Instrument - The electrical instrument is used for measuring electrical quantities likes current, voltage, power, etc.
- c) Electronic Instrument - Electronic instruments use semiconductor devices and thus has quick response time. Ex:- CRO

# Classification of Measuring Instruments

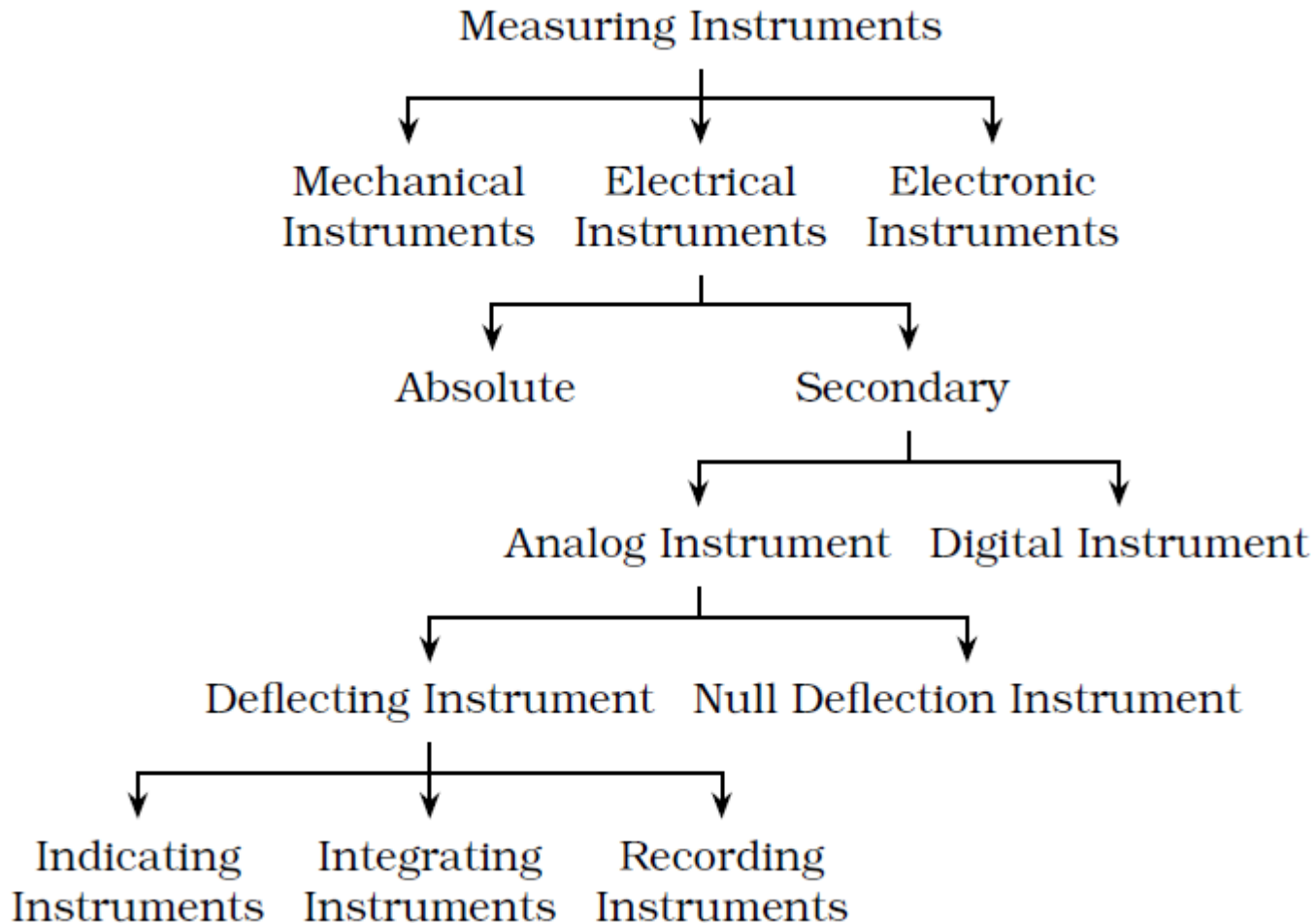



# Different types of electrical instruments are:

## Absolute Instrument

- This type of instrument indicates the value of measuring quantity in terms of instrument constant and its deflection.
- Such instruments do not require comparison with other standards.
- Ex: Tangent galvanometer which gives the measured current in terms of tangent of the deflected angle, the radius and the number of turns of the galvanometer coil.

## Secondary Instrument

- These instruments indicate the magnitude of the measuring electrical quantity. Before using, these instruments require calibration with either an absolute instrument or with an already calibrated secondary instrument.

## Different types of secondary instruments are:

### Analog Instrument

- An analog instrument is one which the output is a continuous function of time, and it bears a constant relationship with the input. Usually it has a pointer-scale mechanism which shows the magnitude of the measured quantities.
- Ex: Ammeter, Voltmeter, Wattmeter, Power factor meter, Frequency meter.

### Digital Instrument

- Signals which vary in discrete steps and have a finite number of possible values within a defined range digital signals and the corresponding instruments are of digital type. The digital instrument gives the output in the numeric form and is more accurate.
- Ex: Odometer, Scoreboard Timer, etc.

## Different types of analog instruments are:

### Null Type Instrument

- Zero or null indication indicates the magnitude of the measured quantity. Null instruments show null deflection when the unknown measuring quantity becomes equal to the known quantity. The null instrument is very sensitive.
- Ex: DC Potentiometer

### Deflection Type Instrument

- Deflection type instrument indicates the measurement of the unknown quantity. In this type of instrument, the measuring quantity produces a deflecting torque. And an opposing torque helps in achieving balance in the instrument.
- Ex: Permanent Magnet Moving Coil, Moving Iron, etc

## Different types of deflection type instruments are:

### Indicating Instrument

- The instrument which indicates the magnitude of the measured quantity is known as the indicating instrument. The magnitude is read out from a pointer and dial/scale arrangement.
- Ex: Voltmeter, ammeter and power factor meter.

### Integrating Instrument

- The instrument totalize events over a specified period of time. The summation, which they give is the product of time and an electrical quantity.
- Ex: Watt-hour meter (Energy meter) and ampere hour meter

## Recording Instrument

- The instrument which records a particular quantity over a specified interval of time is known as the recording instrument. The moving system of the recording instrument carries a pen which lightly touches on the paper sheet.
- The movement of the coil is traced on the paper sheet.
- The curve drawn on the paper shows the variation in the measurement of the electrical quantities.
- Example: ECG, Recording voltmeter in a substation which records the variations of supply voltage in a day.

# Principle of Operation of Analog Instruments

## Magnetic Effect

- When a current carrying conductor is placed in a magnetic field, it experiences a force which causes to move it. This effect is mainly used in instruments like moving iron attraction and repulsion type, permanent magnet moving coil instruments.

## Thermal Effect

- The current to be measured is passed through a small element which gets heated thus increasing its temperature. This temperature rise is converted to an emf with help of a thermocouple attached to the element.

## Electrostatic Effect

- When two plates are charged, there is a force exerted between them, which moves one of the plates. This effect is used in electrostatic instruments like voltmeter.

## Electromagnetic / Induction Effect

- When a non-magnetic conducting disc is placed in an alternating magnetic field, an emf is induced in the disc. If a closed path is provided in the disc, then a flow of current occurs in the disc. The force produced by the interaction of induced currents and the alternating magnetic fields makes the disc move which is called as induction effect. This effect is used in energy meter.

## Hall Effect

- If a strip of conducting material carries current in the presence of a transverse magnetic field, an emf is induced between the two edges of the conductor which can be measured after amplification. This effect is mainly used in magnetic measurements like flux meter, which is used to measure magnetic flux.

# Operating Forces in Measuring Instruments

For satisfactory operation of indicating instrument, three forces are necessary.

They are

1. **Deflecting force** - The deflecting force is required for moving the pointer from its zero position.
2. **Controlling force** - Controlling force is equal and opposite to the deflecting force, It also bring the moving system back to zero when deflecting force is removed
3. **Damping force** - To prevent oscillation of the moving system and helps it to reach its final or steady position quickly.

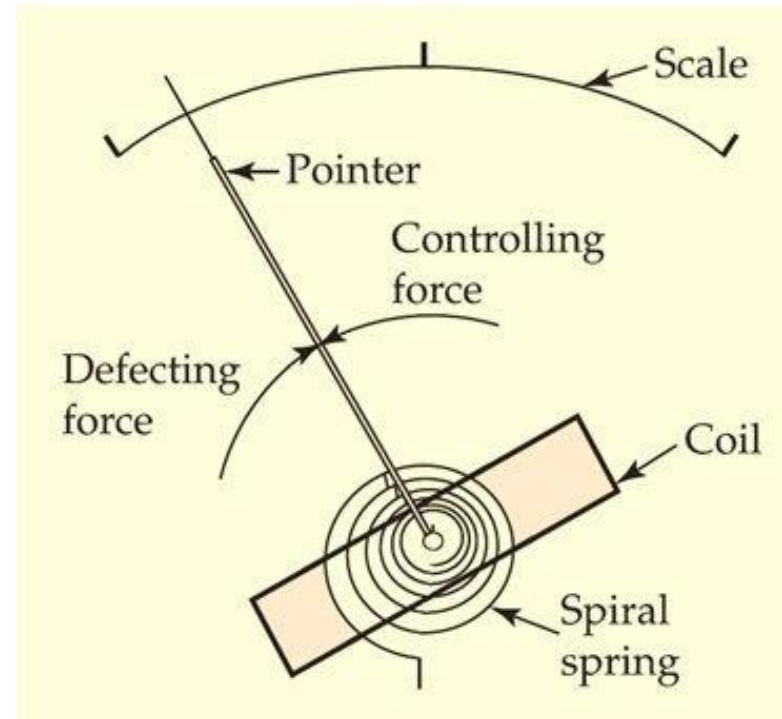



# Deflecting Force & Deflecting System

- When there is no input signal to the instrument, the pointer will be at its zero position.
- To move/deflect the pointer from its zero position to a final position according to the measured quantity, a force(torque) is necessary which is known as deflecting force.
- A system which produces the deflecting force is known as a deflecting system or moving system.
- Generally, a deflecting system converts an electrical signal to a mechanical force.
- The deflecting force is produced by any one of the effects such as magnetic, thermal, electrostatic, electromagnetic/induction, etc.

## Controlling Force & Controlling System

- To make the measurement indicated by the pointer definite (constant) a force is necessary, which will be acting in the opposite direction to the deflecting force.
- This force is known as controlling force.
- A system which produces this force is known as a controlling system. When the external signal to be measured by the instrument is removed, the pointer should return back to the zero position.
- This is possible due to the controlling force and the pointer will be indicating a steady value when the deflecting torque ( $T_d$ ) produced is equal to the controlling torque ( $T_c$ ) produced.

## The controlling torque serves two functions.

1. To produce a force equal and opposite to the deflecting force in order to make the deflection of the pointer at a definite magnitude. In the absence of this system, the pointer will swing beyond its final steady position for the given magnitude and the deflection will become indefinite.
  2. To bring the moving system back to zero position if the deflecting force is removed. In the absence of the controlling system, the pointer will not comeback to zero after the measurement.
- In indicating instruments, the controlling torque is obtained by two methods
    - a) Spring Control
    - b) Gravity Control

# Spring Control

- In this type of control, Two hair springs are provided in opposite direction on either end of spindle which exerts a controlling torque.
- The spring is made of phosphorous bronze.
- The spring used in this method should be Non-magnetic, Free from mechanical fatigue, Should have low temperature and low resistance.

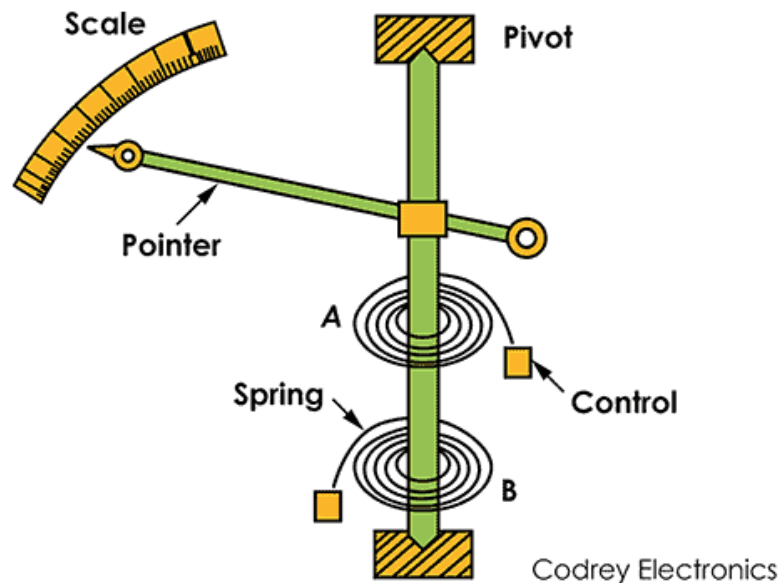

- All meters have current sensing element hence deflecting torque is directly proportional to current ' $I$ ' and  $T_c$  proportional to  $\theta$ . When  $T_c = T_d$  the pointer will come to a steady position.
- Since,  $\theta$  and  $I$  are directly proportional so the scale of such instrument which uses spring controlled is uniform.

### **Advantages of spring control method**

- The instrument can be placed in any position i.e., horizontal as well as vertical.
- This method does not increase the weight of the instrument as springs are light.
- Scale is uniform in this method.

### **Disadvantages of spring control method**

- Temperature variations can affect the length and design of the spring and hence also changes the controlling torque.
- Springs get deteriorated with the time and hence its accuracy is also lost.

## Gravity Control

- In this type of control, a small weight,  $W$  is placed on an arm attached to the moving system to produce the controlling torque due to gravity.
- The control weight is positioned in such a way that it can be adjusted to produce the appropriate amount of controlling torque.
- The control weight is positioned at zero position of the pointer when the system is at rest and the controlling torque at this point is zero.

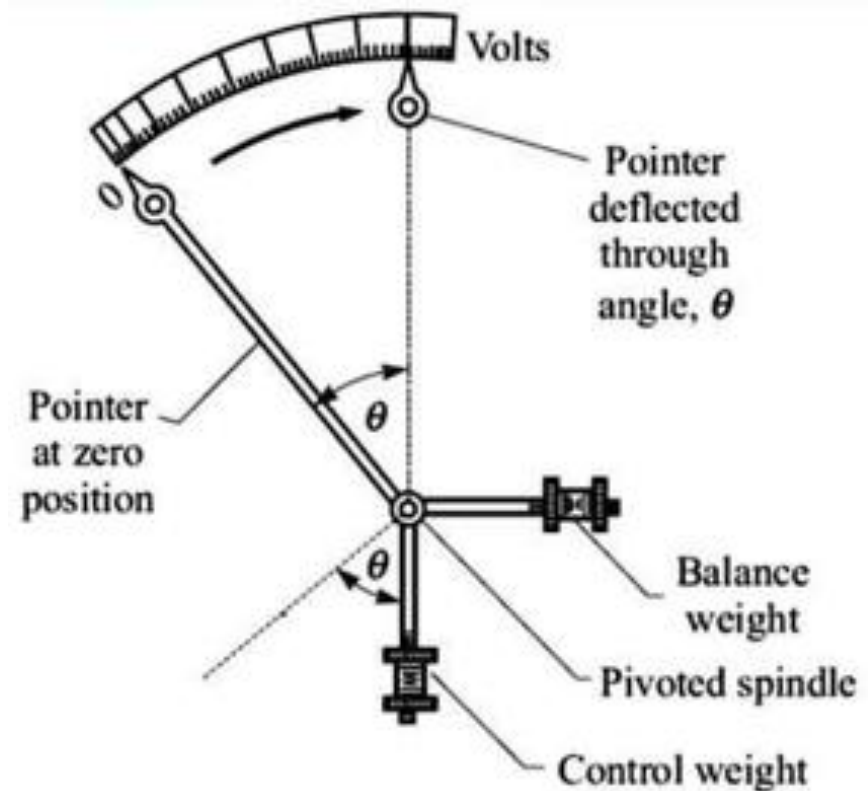

- However, under the action of the deflecting force, the pointer deflects by an angle,  $\theta$  from its zero position and hence the control weight will also move.
- But due to gravity, the control weight would try to come back to its original vertical position and hence produces the necessary controlling torque.
- There are two components of the control weight  $W \sin \theta$  and  $W \cos \theta$ .
- Only the component  $W \sin \theta$  will provide the necessary force for the controlling torque and helps to retain the original position.

$$\text{Thus, } T_c = W \sin \theta$$

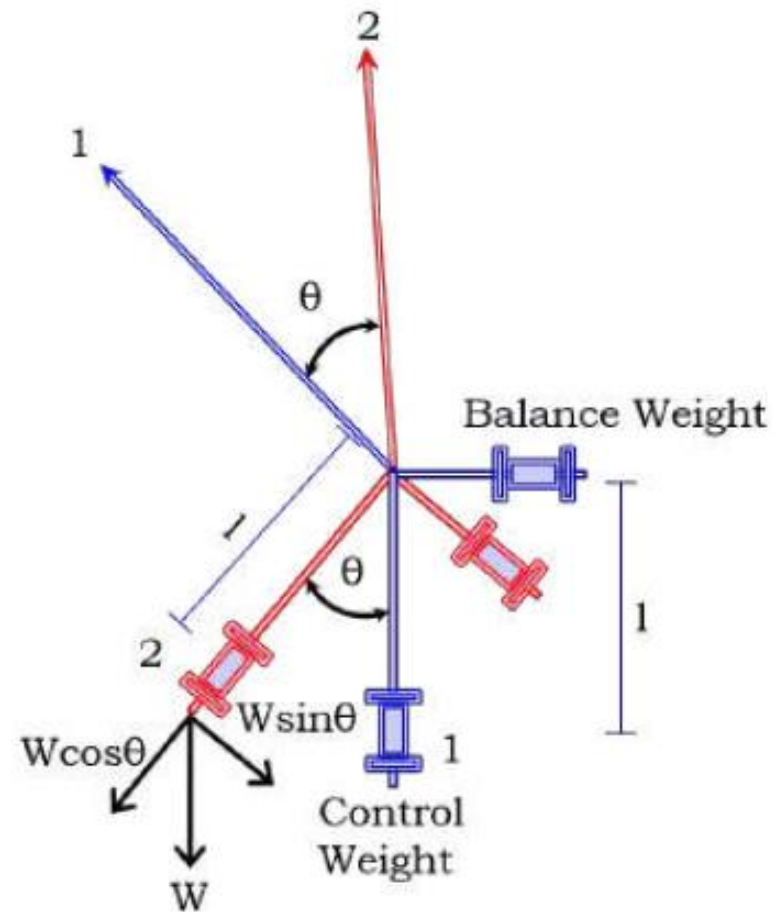

- It seems from the above equation that controlling torque is directly proportional to the sine of the deflected angle.
- Then for position of rest,  $T_d = T_c$  Or current is proportional  $\sin \theta$ .
- Hence in gravity control instruments, the scales are not uniform but are cramped or crowded at their lower ends

### **Advantages of gravity control method**

- It is simple and cheap method.
- Not affected by temperature variations.

### **Disadvantages of gravity control method**

- Have non-uniform scale and thus reading become difficult.
- It increases the weight of the system.
- The instrument should be placed always in the vertical position.



# Damping Force & Damping System

- When a deflecting force is applied to the moving system, it deflects, and it should come to rest at a position where the deflecting force is balanced by the controlling force.
- The deflecting and controlling forces are produced by systems which have inertia and therefore, the moving system cannot immediately settle at its final position but overshoots or swings ahead of it. The force which helps to bring the pointer to rest within short time is called damping force. The system which produces damping force is called a damping system.
- Various methods used for producing damping torque are
  1. Air friction damping
  2. Fluid friction damping
  3. Eddy current damping
  4. Electromagnetic damping

## Air Friction Damping

- In this method, a light aluminum piston is attached to spindle. The piston moves in a rectangular (or circular) air chamber closed at one end. There is very little clearance in chamber for the movement of the piston. When there are oscillations, the piston moves in and out of the air chamber.
- When the pointer moves clockwise, the piston moves out of the air chamber, pressure in the closed space falls, and the pressure on the open side of piston is greater than on the other side and thus the movement of the piston and the moving system is opposed.
- When the pointer moves anti clockwise, the piston moves inside the chamber, the air inside is compressed and pressure of air thus builds up, opposes the motion of piston and hence the whole moving system.

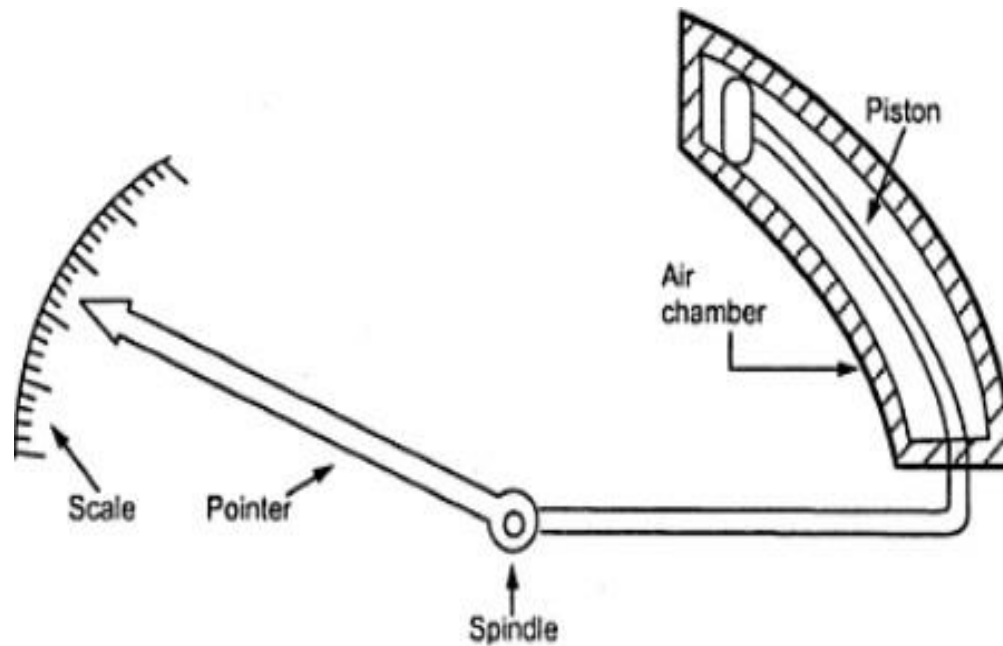

## Fluid Friction damping

- This form of damping is similar to air friction damping.
- Oil is used in place of air and as the viscosity of oil is greater, the damping force is correspondingly greater.
- A disc is attached to the moving system as shown in the figure, this disc dips into an oil pot and is completely submerged in oil.

- When the moving system moves, the disc moves in oil and a frictional drag is produced. This frictional drag always opposes the motion.

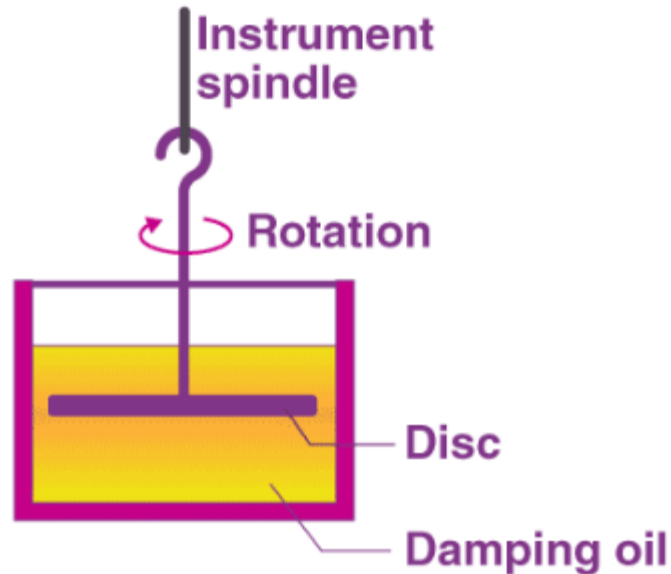

## Eddy Current Damping

- Based on Faraday's law and Lenz's law. An aluminum disc is connected to the spindle.
- A part of the aluminum disc is inserted into the damping magnet which is a permanent magnet.

- When the pointer oscillates, the aluminum disc rotates, cutting the magnetic field and thus emf is induced.
- As a result, eddy current flows through the disc and it opposes the force causing the rotation, thus hunting the pointer oscillation. By putting deeper of the disc into the magnet, the damping force can be increased.

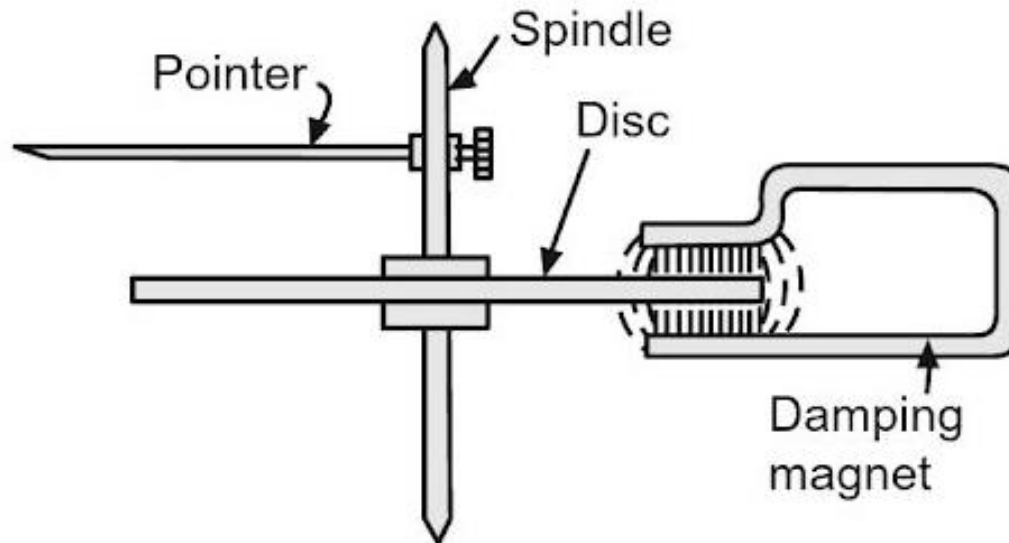

# Electromagnetic Damping

- The movement of a coil in a magnetic field produces a current in the coil which interacts with the magnetic field to produce a torque.
- This torque opposes the movement of the coil and slows the response.

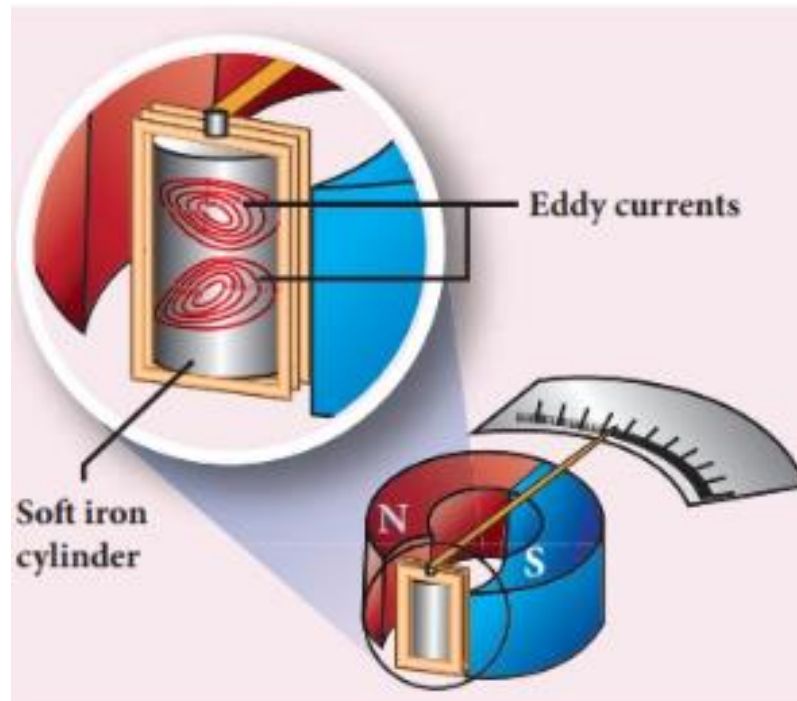

# Damping Methods - Advantages & Disadvantages

## {Comparison of types of damping}

### Air Friction Damping

- It provides a very simple and cheap method of damping.
- Care must be taken to see that the piston is not bent or twisted otherwise it will touch the walls of the air chamber thereby causing serious errors due to solid friction.
- It does not require the use of a permanent magnet whose introduction may lead to distortion of the operating field.

### Fluid Friction Damping

- It has the advantage that the oil which is required for damping, can be used for insulation purposes in some forms of instruments which are submerged in oil.

- Due to more viscosity of fluid, more damping is provided.
- Due to upthrust of oil, the load on the bearings are reduced, thus reducing the frictional errors.
- Disadvantages of fluid friction damping is that it is used only for instruments in vertical position.
- Due to oil leakage, the instruments cannot be kept clean.

## **Eddy Current Damping & Electromagnetic Damping**

- It is the most efficient form of damping.
- It is very convenient to use in instruments where a metallic disc or a former and a permanent magnet already forms part of the operating system.



## Ammeters

- Ammeters are used to measure the current in amperes and are connected in series with the circuit whose current is to be measured.
- The power loss in an ammeter is  $I^2 R_a$  where  $I$  is the current to be measured and  $R_a$  is the resistance of the ammeter.
- Ammeters have low electrical resistance so that they doesn't affect the current to be measured.
- An ideal ammeter will have zero resistance.

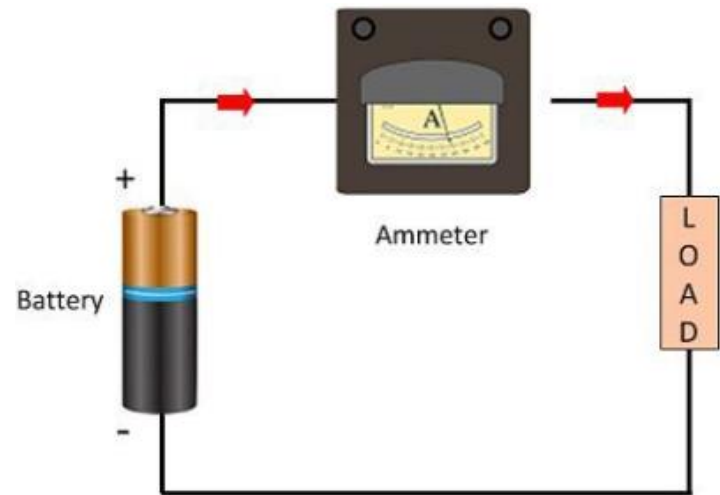
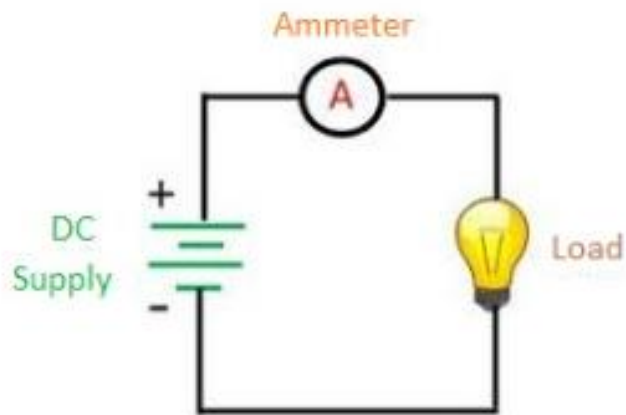

## Voltmeters

- Voltmeters are used to measure the potential difference/voltage in volts and are connected in parallel with the circuit whose potential difference/voltage is to be measured. The power loss in a voltmeter is  $\frac{V^2}{R_v}$ , where  $V$  is the voltage to be measured and  $R_v$  is the resistance of the voltmeter.
- Therefore, voltmeters will have a very high electrical resistance, in order that the current drawn by them is small and consequently the power consumed is also small. An ideal voltmeter will have infinite resistance.

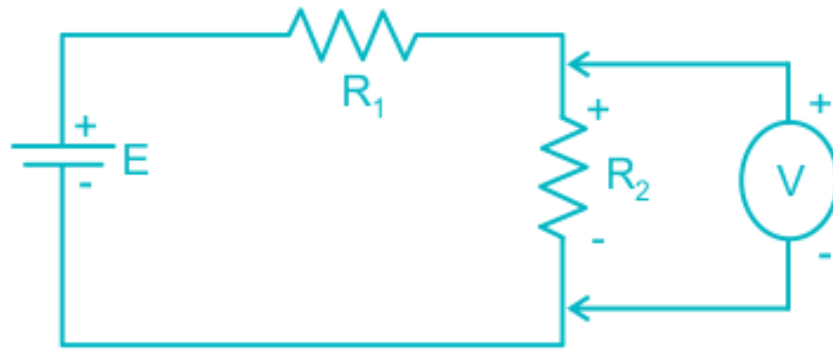

# Permanent Magnet Moving Coil (PMMC) Instruments

- One of the most accurate type of instrument used for D.C. measurements is PMMC instrument.

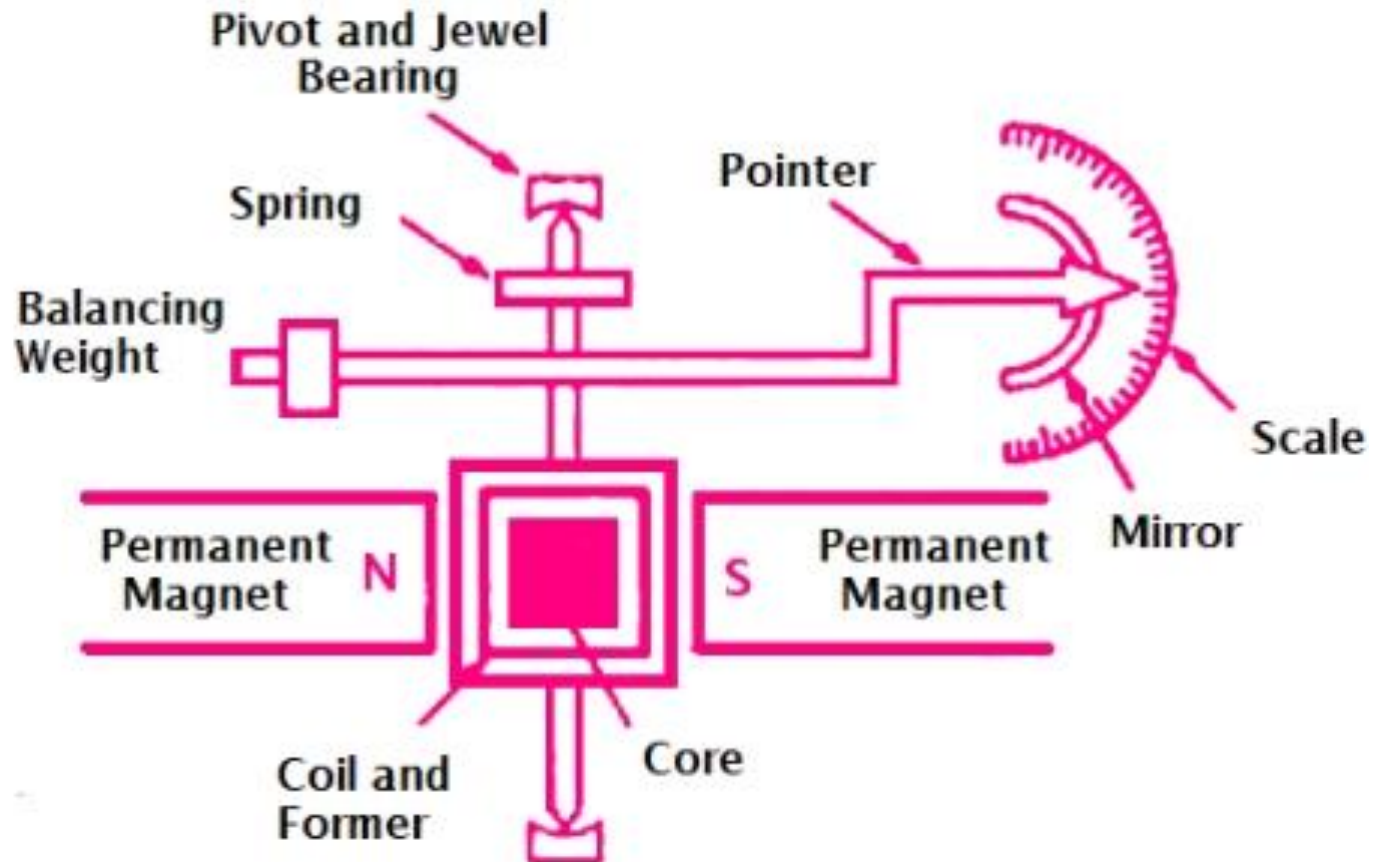

## Construction

- A permanent magnet is used in this type instrument.
- Aluminum former is provided in cylindrical shape in between two poles of the permanent magnet. Coils are wound on the aluminum former which is connected with the spindle. This spindle is supported with jeweled bearing.
- Two hair springs made of phosphor bronze are attached on either end of the spindle which will provide the necessary controlling torque. The springs are spiraled in opposite directions. The terminals of the moving coils are connected to the spring.
- Damping torque is provided by eddy current method and is produced by the aluminum former.
- The pointer and scale mechanism with mirror will help it to read out the measurement value.

## Principle of Operation

- When D.C. supply is given to the moving coil, D.C. current flows through it. When the current carrying coil is kept in the magnetic field, it experiences a force. This force produces a torque, and the former rotates.
- The pointer is attached with the spindle. When the former rotates, the pointer moves over the calibrated scale.
- When the polarity is reversed a torque is produced in the opposite direction. The mechanical stopper does not allow the deflection in the opposite direction and therefore the polarity should be maintained with PMMC instrument.
- If A.C. is supplied, a reversing torque is produced and thus cannot produce a continuous deflection. Therefore, this instrument cannot be used in A.C

# Torque Equation

Let  $T_d =$  deflecting torque

$T_C =$  controlling torque

$\theta =$  angle of deflection

$K =$  spring constant

$b =$  width of the coil

$L =$  Length of coil

$N =$  No. of turns

$I =$  current

$B =$  Flux density

$A =$  area of the coil

The force produced in the coil is given by

$$F = BIL \sin \theta$$

When,  $\theta = 90^\circ$

For  $N$  turns,  $F = NBIL$

Torque produced  $T_d = F \times \perp_r$  distance

$$T_d = NBIL \times b = BINA$$

$$T_d = BAN I$$

$$T_d \propto I$$

- ∴ Deflecting Torque,  $T_d = GI$  ; where,  $G = NBA$  or  $T_d \propto I$
- For spring control, Controlling Torque,  $T_c \propto \theta$  or  $T_c = k\theta$
- For steady deflection,  $T_d = T_c$

$$\theta = \frac{G}{k} * I$$

- ie., the deflection is proportional to the current and the scale is therefore uniformly divided.

### Applications of the PMMC Instruments are:

1. Can be used as dc ammeter and its range can be increased by using a low resistance in parallel with the instrument.
2. When used as dc voltmeter, its range can be increased by using a high resistance in series with it.

## PMMC Instruments - Characteristics

### 1. Full-scale deflection current ( $I_m$ )

- Current needed to deflect the pointer from its initial zero position to final position on the calibrated scale. Vary from  $2\mu\text{A}$  to  $30\text{mA}$ .

### 2. Internal Resistance ( $R_m$ )

- DC ohmic resistance of the wire of the moving coil.
- Ranges from  $1-2\Omega$  for  $30\text{mA}$  to  $2\text{k}\Omega$  for  $50\mu\text{A}$  movement.

### 3. Sensitivity ( $S$ )

- Reciprocal of full-scale deflection current. ( $S = 1/I_m$ ) and Unit is ohm/volt)
- Also known as current sensitivity or sensitivity factor.
- Depends on strength of permanent magnet & number of turns.



## Advantages of the PMMC instruments are:

1. Torque/weight is high
2. Power consumption is less
3. Scale is uniform
4. Damping is very effective
5. Since operating field is very strong, the effect of stray field is negligible
6. Range of instrument can be extended

## Disadvantages of the PMMC instruments are:

1. Cost is high
2. Error is produced due to ageing effect of PMMC
3. Friction and temperature error are present

4. Can be used only for D.C. - If we connect a MC instrument to measure AC, the current through the coil and magnetic field produced will be altering, hence the pointer will keep on moving making it difficult to note the reading. That's why we won't use MC instruments for measuring AC whereas in DC the current will not alter hence the pointer stops at steady state, and the reading can be noted down.

## Errors in PMMC Instruments

The main sources of errors in moving coil instruments are due to:

1. Weakening of permanent magnets due to ageing and temperature effects.
2. Weakening of springs due to ageing and temperature effects.
3. Change of resistance of the moving coil with temperature.

# Extension of Range of MC Instruments

## DC Ammeters

- Range can be extended by connecting a shunt resistor (resistor in parallel), with the ammeter circuit.
- Usually, the shunt resistor should have low values.

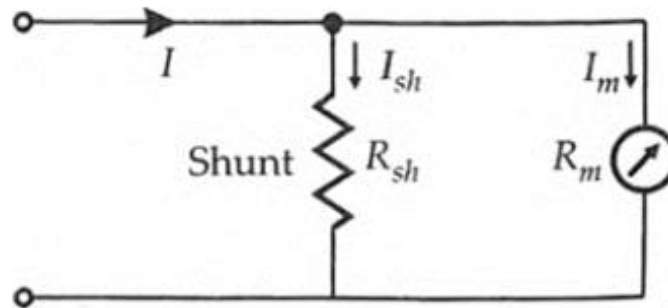

$R_m$  = Internal resistance of movement (i.e., the coil)  $\Omega$ ;

$R_{sh}$  = Resistance of the shunt;  $\Omega$ ,

$I_m = I_f s$  = Full scale deflection current of movement, A;

$I_{sh}$  = Shunt current, A

$I$  = Current to be measured; A.

- Since the shunt resistance is in parallel with the meter movement, the voltage drops across shunt and movement must be the same.

$$I_{sh} R_{sh} = I_m R_m$$

$$I_{sh} = I - I_m$$

$$R_{sh} = I_m R_m / I_{sh}$$

$$R_{sh} = I_m R_m / (I - I_m)$$

Multiplying power,

$$m = I / I_m$$

$$m = 1 + \frac{R_m}{R_{sh}}$$

Resistance of shunt,

$$R_{sh} = \frac{R_m}{m - 1}$$

- The range of an ammeter can be extended by using a shunt. Hence, by adding a number of shunts, it can be used as a multirange ammeter and such arrangement is shown below.
- It consists of three shunts  $R_{sh1}$ ,  $R_{sh2}$ , and  $R_{sh3}$  which can be used for three different current ranges  $I_1$ ,  $I_2$ , and  $I_3$  respectively.
- Let the shunt multiplying factors of the currents  $I_1$ ,  $I_2$ , and  $I_3$  be  $m_1$ ,  $m_2$  and  $m_3$  respectively. Therefore,

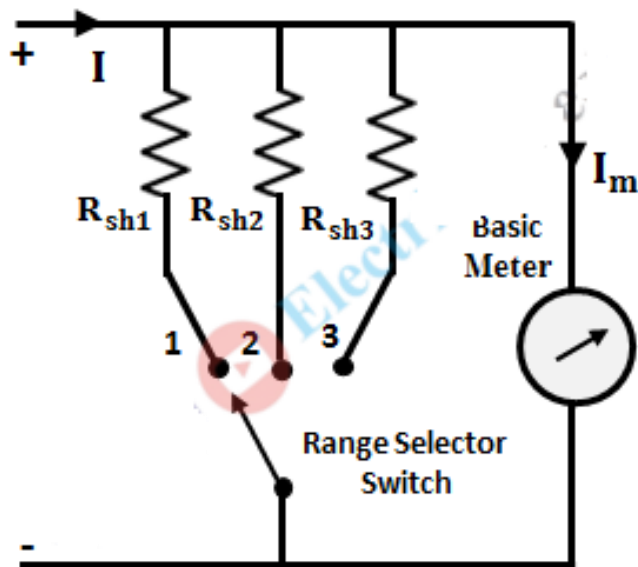

$$R_{sh1} = \frac{R_m}{m_1 - 1}, R_{sh2} = \frac{R_m}{m_2 - 1}$$

$$R_{sh3} = \frac{R_m}{m_3 - 1}$$

## DC Voltmeters

- Range can be extended by adding a series resistor or multiplier with the voltmeter circuit. Usually, the multiplier should be having large values.

$I_m = I_{fs}$  = Full scale deflection current of meter,

$R_m$  = Internal resistance of meter movement,

$R_s$  = Multiplier resistance,

$v$  = Voltage across the meter movement for current  $I$ ,

$V$  = Full range voltage of instrument.

$$v = I_m R_m$$

$$V = I_m (R_m + R_s)$$

$$R_s = \frac{V - I_m R_m}{I_m} = \frac{V}{I_m} - R_m$$

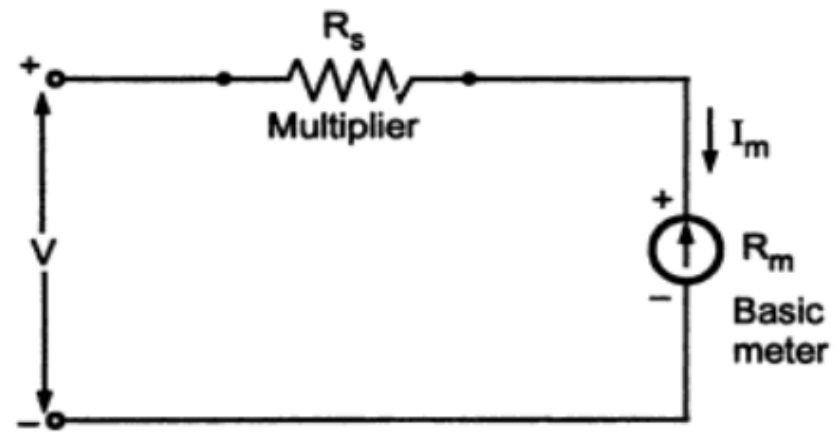

Multiplying factor for multiplier,

$$m = \frac{V}{v} = \frac{I_m (R_m + R_s)}{I_m R_m} = 1 + \frac{R_s}{R_m}$$

Resistance of multiplier,

$$R_s = (m - 1) R_m$$

- Hence for the measurement of voltage  $m$  times the voltage range of the instrument, the series multiplying resistance should be  $(m - 1)$  times the meter resistance.

## Multi Range Voltmeter

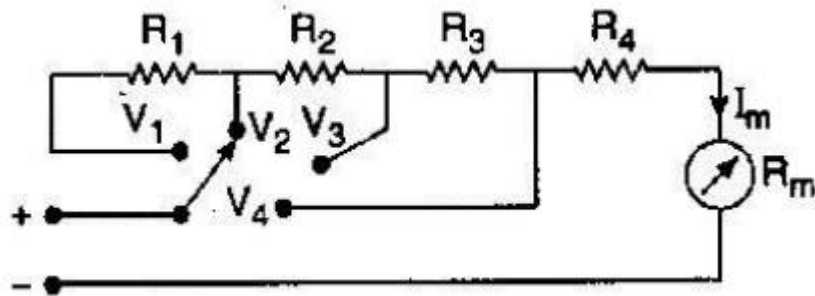

$$R_{s1} = \frac{V_1}{I_m} - R_m$$

$$R_{s2} = \frac{V_2}{I_m} - R_m$$

$$R_{s3} = \frac{V_3}{I_m} - R_m$$

$$R_{s4} = \frac{V_4}{I_m} - R_m$$

## Moving Iron (MI) Instruments

- One of the most accurate instrument is used for both AC and DC measurement is Moving Iron instrument.
- There are two types of moving iron instruments:
  1. Attraction type Moving Iron instrument
  2. Repulsion type Moving Iron instrument

### Attraction Type

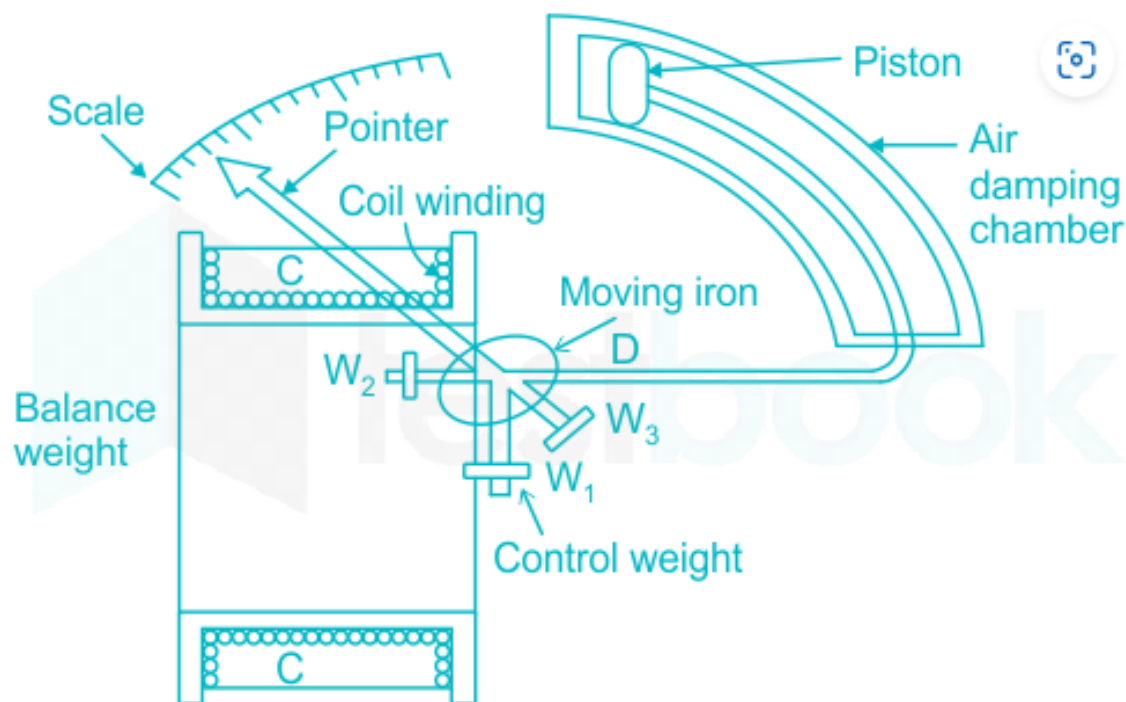



## Construction

- It consists of a coil wound on a hollow cylindrical bobbin.
- A small piece of soft iron is eccentrically pivoted just outside the coil.
- A pointer is attached to the spindle so that it is deflected with the motion of the soft iron piece.
- The spindle is pivoted to jewel bearings.
- Air friction damping is used - A piston, attached to the spindle, moves inside an air chamber and gives the necessary damping.
- The attraction type instruments use spring, which provides the controlling torque. (For horizontally mounted MI instruments spring control is used for providing controlling torque and Vertically mounted instruments gravity control is used. )

## Working

- When current flows through this coil, it creates a magnetic field, and it attracts the soft iron piece towards it.
- The force of attraction depends on the current flowing through the coil
- This movement is transferred to a pointer across a calibrated scale through a linkage mechanism. The result is that the pointer attached to the moving system moves from zero position.
- The pointer will come to rest at a position where deflecting torque is equal to the controlling torque.
- If current in the coil is reversed, the direction of magnetic field also reverses and so does the magnetism produce in the soft iron piece.

- Hence the direction of the deflecting torque remains unchanged. For this reason, such instruments can be used for both ac and dc measurements.

## Repulsion Type MI Instrument

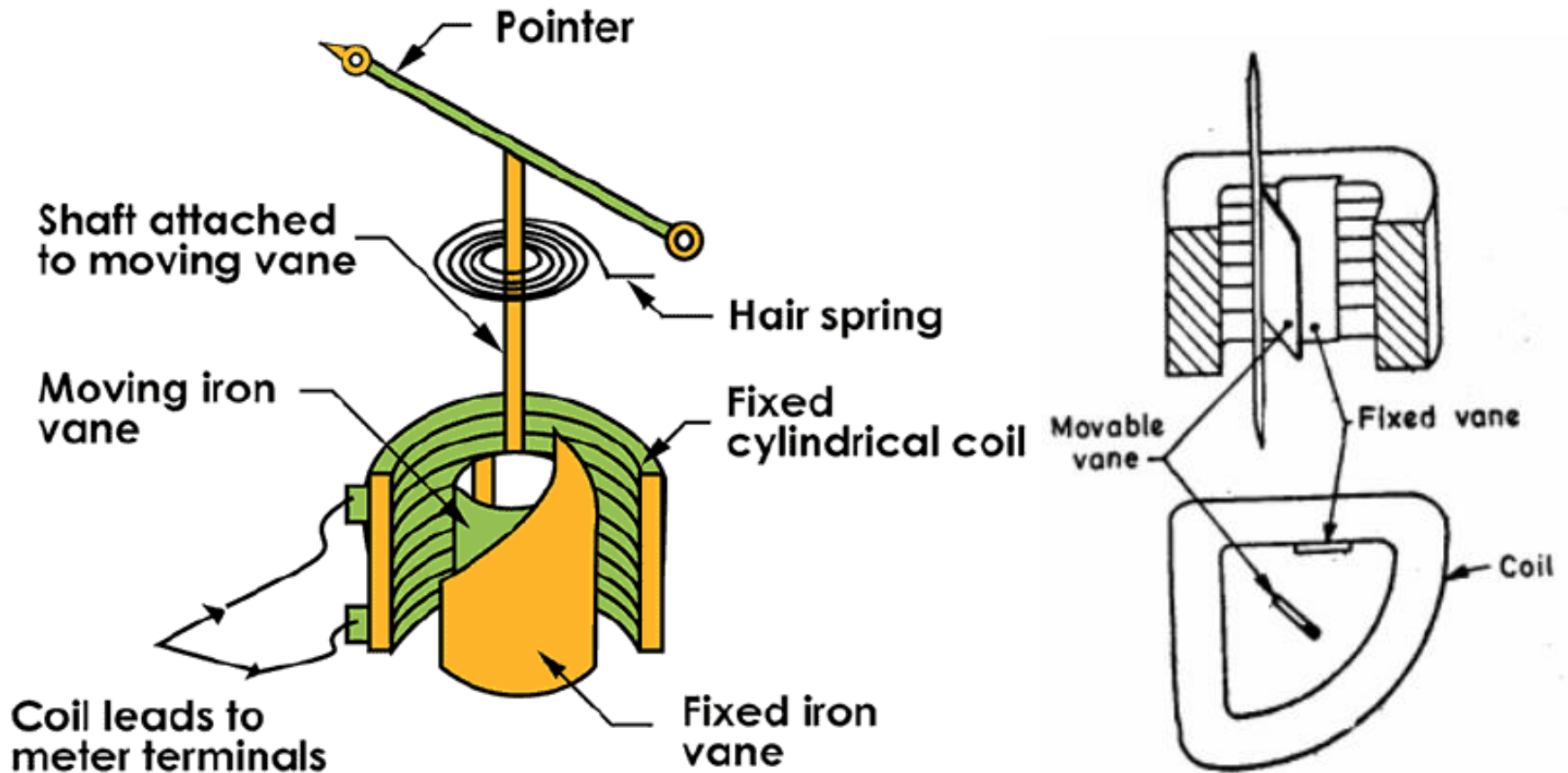

**(a) Radial vane type.**

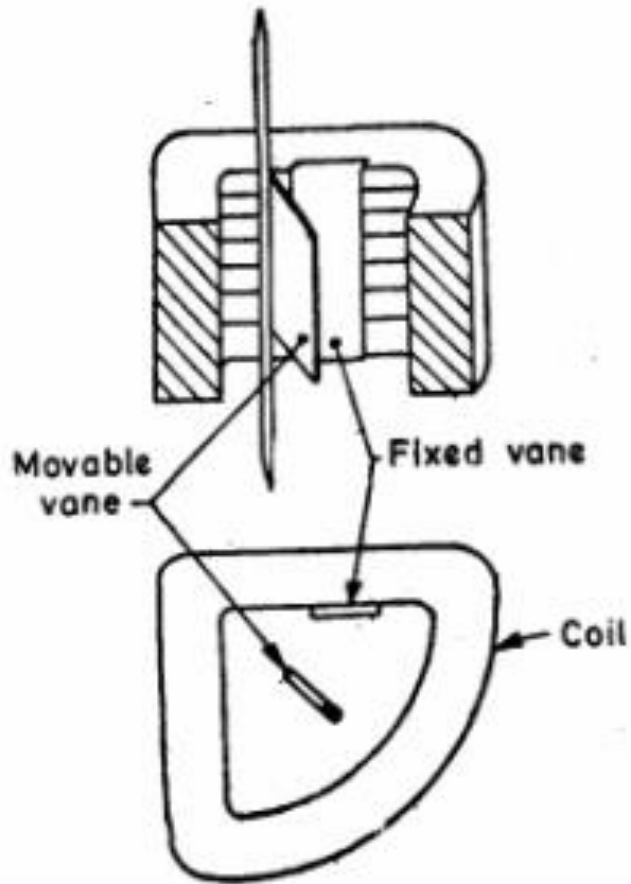

**(b) Co-axial vane type**

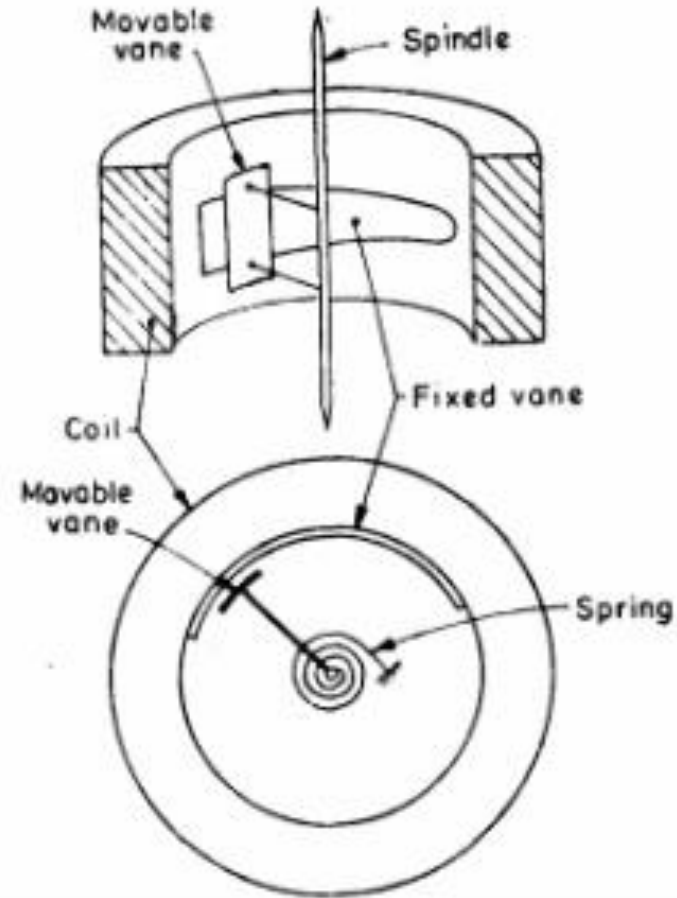

## Construction & Working

- The repulsion type instrument has two vanes or iron plates.
- One is fixed, and the other one is movable.
- The vanes become magnetized when the current passes through the stationary coil and the force of repulsion occur between them.
- Because of a repulsive force, the moving coil starts moving away from the fixed vane.
- The spring provides the controlling torque.
- The air friction induces the damping torque, which opposes the movement of the coil.

## Torque Equation of MI instrument

- Normally current flows through the coil

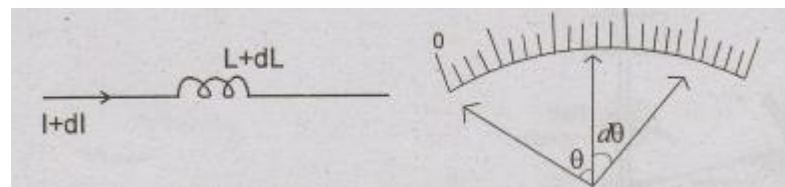
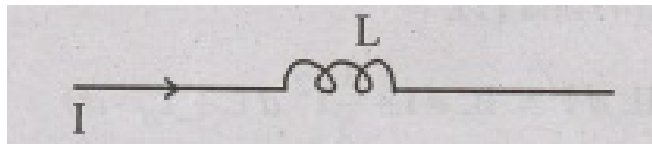

- Now a small increment in current is supplied to the coil, it result in a small increment in deflection.

$$\text{Mechanical work done} = T_d d\Theta \dots\dots\dots(1)$$

$$\text{emf, } e = d/dt (L I)$$

$$e = I dL/dt + L dI/dt \dots\dots\dots(2)$$

Electrical energy supplied is given by, multiply  $I \cdot dt$  on both sides of equation (2),

$$eI dt = I^2 dL/dt \cdot dt + L I dI/dt \cdot dt$$

$$eI dt = I^2 dL + L I dI \dots\dots\dots(3)$$

Stored energy changes from  $\frac{1}{2} I^2 L$  to  $\frac{1}{2} (I + dI)^2 (L + dL)$

Change in stored energy is

$$\frac{1}{2} (I^2 + 2 I dI + dI^2) (L + dL)$$

Neglecting second and higher order terms,

$$IL dI + \frac{1}{2} dL \dots\dots(4)$$

By the principle of conservation of energy,

Electrical energy supplied = increase in stored energy + mechanical work done.

From equation (3), (4) and (1),

$$I^2 dL + I L dI = IL dI + \frac{1}{2} I^2 dL + T_d \cdot d\Theta$$

$$T_d \cdot d\Theta = I^2 dL - \frac{1}{2} I^2 dL$$

$$T_d \cdot d\Theta = \frac{1}{2} I^2 dL$$

$$T_d = \frac{1}{2} I^2 dL/d\Theta \dots\dots\dots(5)$$

$$T_c = K \Theta \dots\dots\dots(6)$$

For final steady deflection,  $T_c = T_d$

.. from equation (5) and (6),

$$K\Theta = \frac{1}{2} I^2 \cdot dL/d\Theta$$

$$\text{Deflection, } \Theta = \frac{1}{2} I^2 / K \cdot dL/d\Theta$$

- Deflection is directly proportional to the square of the rms value of the measuring current. Therefore, the scale is nonlinear.
- Torque is unidirectional, so MI instrument is not polarity sensitive.

## Applications of MI Instruments

- Widely used as ammeters and voltmeters for DC and AC.
- Can be easily constructed for ranges of 0.1A to 30A without the use of shunt.



## Advantages of the MI instruments are:

1. **Universal use:** The MI instrument is independent of the direction of current and hence can be used for both AC and DC.
2. **Less Friction Error:** The friction error is very less in the moving iron instrument because of their high torque to weight ratio. The torque to weight ratio is high because their current carrying part is stationary and the moving parts are lighter in weight.
3. **Affordable:** The MI instruments require less number of turns in the coil as compared to PMMC instrument and thus it is cheaper.
4. **Robustness & Reliability:** The instrument is robust because of their simple construction and give reliable service.

## Disadvantages of the MI instruments are:

1. **Non-Uniform Scale:** The scale of the moving iron instruments is not uniform, and hence accurate reading is not possible especially in the cramped region of the scale.
2. **Errors:** Some serious error occurs in the instruments because of the hysteresis, frequency and stray magnetic field.
3. **Waveform Error:** These instruments may be seriously affected by the nature of flux waveform.
4. **Sensitivity:** Not as sensitive as the PMMC instruments.

## Difference between AC and DC calibration

- The calibration of the AC and DC are different because of the effect of the inductance of meter and the eddy currents present when used in AC. For AC calibration is done for the frequency at which they use.

## Extension of Range of MI Instruments - AC Ammeters

- Shunts are not used to extend the range of the AC(MI) Ammeters. Because the division of current between the operating coil and the shunt varies with the frequency.

The range of the ammeters can be extended by:

- Changing the number of turns of the operating coil. The ammeter can have different ranges by merely having different number of turns on the coil. Since the coil carries the whole current to be measured, it has few turns of thick wire. The range obtained by this method are 0-250A.

### Using Instrument Transformer

- For ranges above 0-250A, a current transformer is used in conjunction with low range (0-5A) AC Ammeter. Current transformer is a step-up transformer. Primary of this transformer is connected in series with the load and carries the load current, whereas the low range AC Ammeter is connected across the secondary of the transformer.

## AC Voltmeters

The range of the voltmeters can be extended by:

### Using Multiplier

- By connecting a high resistance (multiplier) in series with the voltmeter. Cannot be used where excessive power is wasted in the multiplier. Can be used up to the range 0-750V.

### Using Instrument Transformer

- For ranges above 0-750V, a potential transformer is used in conjunction with low range (0-150V) AC Voltmeter. Potential transformer is a step-down transformer. Primary of this transformer is connected across the load which the voltage is to be measured and secondary is connected to low range AC Voltmeter.

## Numerical Problems

A voltmeter having a sensitivity of  $1000\ \Omega/V$  reads  $100\text{ V}$  on its  $150\text{ V}$  scale, when connected across an unknown resistor in series with a multi-ammeter when the milliammeter reads  $5\text{ mA}$ . Calculate

- Apparent resistance of the unknown resistor
- Actual resistance of the unknown resistor
- Error due to the loading effect of voltmeter.

Solution

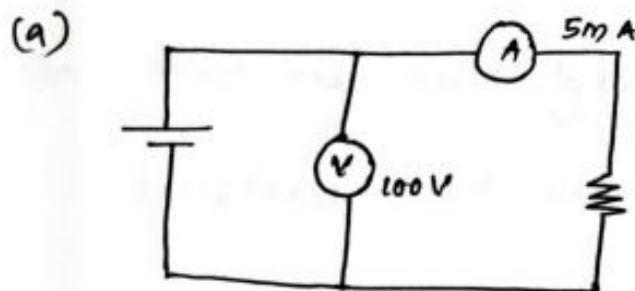

Total circuit resistance,

$$R_T = \frac{100}{5 \times 10^{-3}} = \underline{\underline{20\text{ k}\Omega}}$$

Neglecting the resistance of milli-ammeter the value of unknown resistor,  $R_x = 20 \text{ k}\Omega$

(b) Resistance of voltmeter,  $R_V = 1000 \times 150 = 150 \text{ k}\Omega$

Since the voltmeter and unknown resistance are in parallel

$$\text{Total resistance, } R_T = \frac{R_x \cdot R_V}{R_x + R_V}$$

$$20 \text{ k}\Omega = \frac{R_x \cdot 150 \text{ k}}{R_x + 150 \text{ k}}$$

$$R_x = \underline{\underline{23.077 \text{ k}\Omega}}$$

$$\text{(c) } \% \text{ Error} = \frac{\text{Measured Value} - \text{True Value}}{\text{True Value}} \times 100$$

$$= \frac{20 - 23.077}{23.077} \times 100 = \underline{\underline{-13.33 \%}}$$

Qn. A 1mA meter with an internal resistance of  $100\ \Omega$  is to be converted into a 0-100mA ammeter.

Calculate the shunt resistance required.

$$I_m = 1\text{ mA} = 1 \times 10^{-3}\text{ A}$$

$$R_m = 100\ \Omega$$

$$I = 100\text{ mA} = 100 \times 10^{-3}\text{ A}$$

$$R_{sh} = \frac{I_m \times R_m}{I - I_m} = \frac{1 \times 10^{-3} \times 100}{(100 \times 10^{-3} - 1 \times 10^{-3})} = \underline{\underline{1.01\ \Omega}}$$

Qn. Find the multiplying power of a shunt of  $200\ \Omega$  resistance used with a galvanometer of  $1000\ \Omega$  resistance. Determine the value of shunt resistance to give a multiplying power of 50.

$$R_m = 1000\ \Omega$$

$$R_{sh} = 200\ \Omega$$

$$\text{Multiplying power, } m = 1 + \frac{R_m}{R_{sh}} = \underline{\underline{6}}$$

When  $m = 50$

$$R_{sh} = \frac{R_m}{m-1} = \frac{1000}{50-1} = \underline{\underline{20.4\ \Omega}}$$



Qn. A moving coil ammeter has a fixed shunt of  $0.02\ \Omega$ . With a coil resistance of  $R = 1000\ \Omega$  and a potential difference of  $500\text{mV}$  across it, full scale deflection is obtained.

(a) To what shunted current does this correspond.

(b) Calculate the value of  $R$  to give full scale deflection when shunted current  $I$  is  $10\text{A}$ .

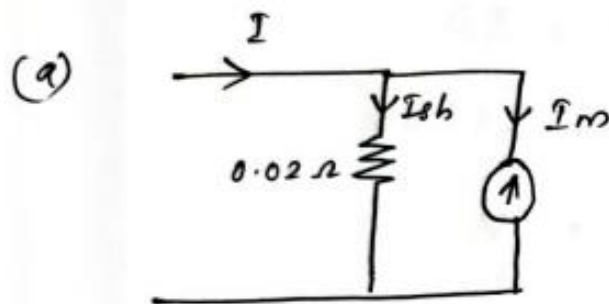

$$I_{sh} = \frac{500 \times 10^{-3}}{0.02} = \underline{\underline{25\text{A}}}$$

$$I_m = \frac{500 \times 10^{-3}}{1000} = \underline{\underline{0.5 \times 10^{-3}\text{A}}}$$

$$(b) I_{sh} = 10 A$$

$$\text{Voltage across shunt} = 10 \times 0.02 = \underline{\underline{0.2 V}}$$

$$\text{Resistance of the meter} = \frac{0.2}{0.5 \times 10^{-3}} = \underline{\underline{400 \Omega}}$$

Ans. A permanent magnet moving coil instrument has a coil dimensions  $15 \text{ mm} \times 12 \text{ mm}$ . The flux density in the air gap is  $1.8 \times 10^{-3} \text{ Wb/m}^2$  and spring constant is  $0.14 \times 10^{-6} \text{ Nm/rad}$ . Determine the number of turns required to produce an angular deflection of  $90^\circ$  when a current of  $5 \text{ mA}$  is flowing through the coil.

At equilibrium,

$$T_d = T_c$$

$$GI = k\theta$$

$$NBlbI = k\theta$$

$$N = \frac{k\theta}{BlbI}$$

$$= \frac{0.14 \times 10^{-6} \times \pi/2}{1.8 \times 10^{-3} \times 15 \times 10^{-3} \times 12 \times 10^{-3} \times 5 \times 10^{-3}} = \underline{\underline{136}}$$

$$\theta = 90^\circ = \frac{\pi}{2} \text{ rad}$$

$$k = 0.14 \times 10^{-6}$$

$$B = 1.8 \times 10^{-3} \text{ Wb/m}^2$$

$$l = 15 \times 10^{-3} \text{ m}$$

$$b = 12 \times 10^{-3} \text{ m}$$

$$I = 5 \times 10^{-3} \text{ A}$$

Qn. A moving coil voltmeter with a resistance of  $20\ \Omega$  gives a full scale deflection of  $120^\circ$ , when a potential difference of  $100\text{ mV}$  is applied across it. The moving coil has dimensions of  $30\text{ mm} \times 25\text{ mm}$  and is wound with 100 turns. The control spring constant is  $0.375 \times 10^{-6}\text{ Nm/deg}$ . Find the flux density in the air gap.

Given that,

$$\theta = 120^\circ$$

$$l = 30 \times 10^{-3}\text{ m}$$

$$N = 100$$

$$V = 100\text{ mV}$$

$$b = 25 \times 10^{-3}\text{ m}$$

$$K = 0.375 \times 10^{-6}\text{ Nm/deg}$$

$$R = 20\ \Omega$$

$$R = 20\ \Omega$$

Current through the instrument for full scale

deflection,  $I = \frac{V}{R} = \frac{100 \times 10^{-3}}{20} = \underline{\underline{5 \times 10^{-3} \text{ A}}}$

Deflecting torque,  $T_d = NBLbI$

controlling torque,  $T_c = k\theta$ .

At final steady state position,  $T_d = T_c$

$$NBLbI = k\theta$$

$$B = \frac{k\theta}{NBLdI}$$

$$= \frac{0.375 \times 10^{-6} \times 120}{100 \times 80 \times 10^{-3} \times 25 \times 10^{-3} \times 5 \times 10^{-3}} = \underline{\underline{0.12 \text{ Wb/m}^2}}$$

# Previous Year University Questions

## June 2024

1. Draw the block diagram of a typical measurement system and indicate the functional elements(3 Marks)
2. Illustrate the classification of different types of errors in measurements. (3 Marks)
3. Illustrate different torques acting on moving system of an indicating instrument with help of neat diagram.(7 Marks)
4. With the help of neat diagrams, explain the construction of attraction type moving iron instrument. Derive the expression for deflecting torque.(7 Marks)
5. The inductance,  $L$  of a spring controlled moving iron meter is given by the following expression,  $L = 1 + 0.0716\theta - 0.0114\theta^2$  milli Henry where  $\theta$  is deflection in radians. Control torque constant is  $0.57 \times 10^{-3} \text{ Nm/rad}$ . Calculate (a) the current for full scale deflection of  $120^\circ$ . (4 Marks) (b) Current for one half of full-scale deflection. (3 Marks)
6. Discuss how the range of an instrument can be extended using shunts and multipliers.(7 Marks)

# Previous Year University Questions

## December 2023

1. Find the multiplying factor of a shunt of 200 ohms resistance used with PMMC of 1000 Ohms resistance. (3 Marks)
2. What are the different standards of measurements. (3 Marks)
3. With the help of neat diagram describe the construction and working of attraction type and repulsion type moving iron instrument. (14 Marks)
4. Discuss different types of damping. What is the necessity of damping and how damping is provided in PMMC instrument? (8 Marks)
5. Draw the block diagram of a typical measurement system and indicate the functional elements in detail. (6 Marks)

## December 2022

1. Define the following terms in measurement (3 Marks)  
Accuracy, Precision, Resolution
2. Explain three methods to provide deflecting torque in electrical instruments. (3 Marks)
3. Explain two mechanisms for producing control torque in electrical measuring instruments with neat diagrams. (4 Marks)
4. With the help of neat diagrams, explain the construction of attraction type moving iron instrument. Prove that the deflecting torque in moving iron instrument is proportional to square of the current being measured. (10 Marks)
5. Explain three mechanisms for producing damping torque in electrical measuring instruments with neat diagrams. (6 Marks)
6. Explain how the range of instrument can be extended in PMMC ammeter and voltmeter? (8 Marks)



## December 2021

1. Define the following terms in measurement  
i) Accuracy ii) Resolution iii) Precision (3 Marks)
2. What are the different standards of measurements? (3 Marks)
3. Explain with neat diagram the construction and principle of operation of a PMMC instrument. Derive the expression for deflection. (7 Marks)
4. Derive the expression for deflection for spring-controlled attraction type moving iron instrument. Also explain the type of damping provided in moving iron instruments. (7 Marks)
5. What is the different torques needed for proper operation of an indicating instrument? (8 Marks)

6. The coil of a measuring instrument has a resistance of  $1\Omega$  and the instrument has a full-scale deflection of  $250V$  when a resistance of  $4999\Omega$  is connected in series with it. Find
- The current range of the instrument when used as an ammeter with the coil connected across a shunt of  $1/499\Omega$ .
  - The shunt resistance for the instrument to give a full-scale deflection of  $50A$ .

## December 2020

1. Explain the significance of measurements. (3 Marks)
2. How drift affects the input-output relationship. (3 Marks)
3. What is controlling force? Explain the various controlling systems used in an indicating instrument? (6 Marks)
4. Explain the various methods for producing damping torque with neat figures. (8 Marks)
5. With neat sketches explain the construction of a PMMC instrument. (8 Marks)
6. "PMMC instruments have uniform linear scale". Justify. (6 Marks)

